

ABRASIVE SEPARATORS

U.S. Seal's abrasive separators provide a simple yet extremely effective method of keeping dirt and other abrasives from the sealing faces - a method that can increase seal or packing life many times over to greatly reduce replacement and maintenance costs. Connected to the discharge side of the pump, the separator takes the abrasive-laden fluid and removes foreign bodies completely. The clean fluid is then injected into the gland housing over the seal faces. This is particularly important in plant start ups where foreign particles are invariably present in the liquid. It also permits the taking of service water from streams, rivers, lakes, and other sources containing abrasives without the usual wear to seals or packings.

Operation

Principle: Liquid piped from the pump discharge enters the feed tap and is rotated inside the cone shaped bore at a velocity dependent on the pressure differential. The particles in the liquids being of greater densities remain close to the tapered wall of the cone and are forced downward to the discharge outlet at the bottom of separator. From there, they are piped with a small amount of liquid to a lower pressure point in the system. No liquid is lost. The clean liquid rises up through the outlet at the top of the separator and is then piped to the housing for flushing the seal faces or lantern gland if packings are used.

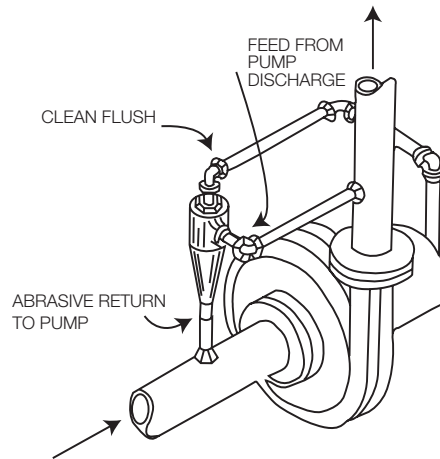

Conditions

1. Minimum pressure differential of 20 psi should be maintained between feed and overflow.
2. Specific gravity of the particles being separated must be greater than the liquid.
3. Centrifugal separators are only effective with inherent abrasives such as sand, small particles of iron oxide, scaly substances, or other natural debris. In contrast, chromates and any substances that are dissolved in the liquid cannot be removed by a centrifugal separator.

KY-1

Material: Nylon

Temperature Range: 0°F to +240°F

Pressures up to 650 PSI

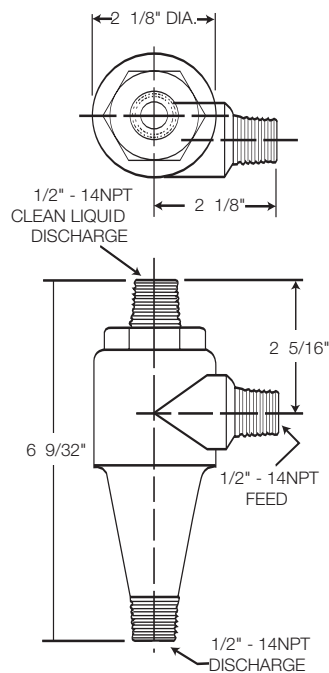

KY-3SS

Material: 316SS

Temperature Range: -20°F to +400°F

Pressures up to 2000 PSI

